

# MEJIX®

## PONCEUSE ORBITALE BRUSHLESS *(Notice originale)*

- EN - BRUSHLESS ORBITAL SENDER *(Original manual translation)*
- DE - KERNBOHRMASCHINE FÜR BETON *(Übersetzung aus dem Original-Anleitung)*
- NL - LIJADORA ORBITAL SIN ESCOBILLAS *(Vertaling van de originele instructies)*
- IT - LEVIGATRICE ORBITALE BRUSHLESS *(Traduzione dell'avvertenza originale)*
- ES - LIJADORA ORBITAL SIN ESCOBILLAS *(Traducción del manual de instrucciones original)*
- PT - LIXADORA ORBITAL SEM ESCOVAS *(Tradução do livro de instruções original)*

BOS 5.0



MPO

180715-A-20260202



mejix.fr

180715





# A

## Description et repérage des organes de la machine

*Description and location of machine parts*





# C

**Contenu du carton**  
Contents of box

**MEJIX**

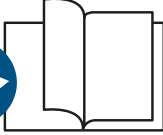
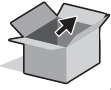

FR

Éléments d'emballage



FR

Cet appareil,  
ses accessoires  
et cordons  
se recyclent

À DÉPOSER  
EN MAGASIN



OU

À DÉPOSER  
EN DÉCHÈTERIE



Points de collecte sur [www.quefairedemesdechets.fr](http://www.quefairedemesdechets.fr)  
Privilégiez la réparation ou le don de votre appareil !



2 x Gr 120  
2 x Gr 180  
2 x Gr 240





# D

## Assemblage de la machine Machine assembly



### Montage du tube

Rohrmontage  
Buis montage  
Conjunto de tubos  
Carregar a bateria  
Assemblaggio del tubo  
Montagem de tubo  
Tube assembly



01

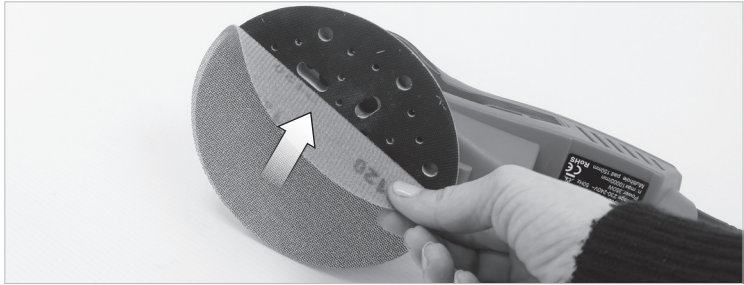

02

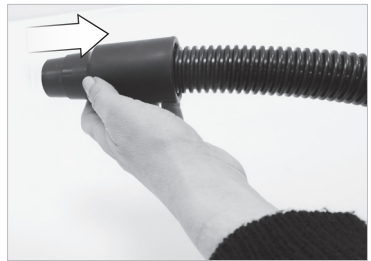

05

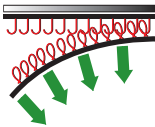

02

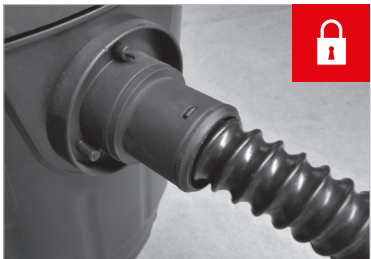



# D

## Utilisation de la machine Machine use

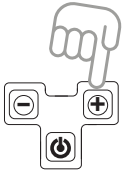

03

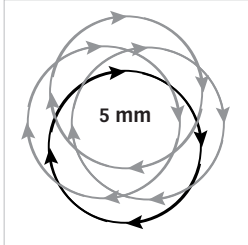
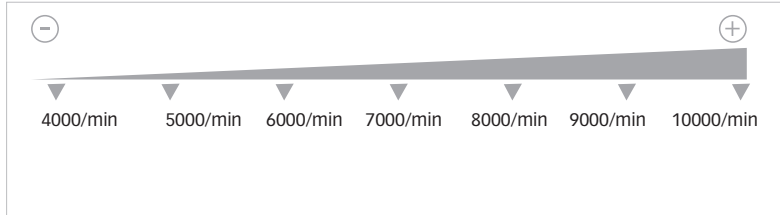



	<p>Porter des lunettes de sécurité : Porter un masque anti-poussière: Porter une protection auditive: porter des gants :</p> <p>Schutzbrille tragen : Staubschutzmaske tragen : Gehörschutz tragen: Handschuhe tragen:</p> <p>Draag een veiligheidsbril : Draag een stofmasker : Draag gehoorbeschermers: draag handschoenen:</p> <p>Llevar puestas gafas protectoras : Llevar puesta una careta de protección contra el polvo : Llevar puesta una protección auditiva: usar guantes</p> <p>Portare de gli occhiali di sicurezza : Indossare una mascherina anti-polvere : Portare una protezione uditiva: indossare i guanti:</p> <p>Utilizar óculos de seguridad : Utilizar una mascarã anti-poeira : Utilizar uma protecção auditiva: usar luvas:</p> <p>Wear protective eyewear : Wear a dust mask : Wear hearing protective equipment: wear gloves :</p>	<b>X</b>
	<p>Lire les instructions avant usage : Lees voor het gebruik de instructies : Léase las instrucciones antes de usar : Ler as instruções antes da utilização : Leggere le istruzioni prima dell'uso : Read the instructions before use :</p>	<b>X</b>
	<p>Vitesse à vide: Leerlaufdrehzahl: Velocidad vacía: Velocidade no vácuo: Velocità a vuoto: No-load speed:</p>	<b>4000-10 000 min<sup>-1</sup></b>
	<p>Puissance assignée: Onbelast toerental: Potencia fijada: Potência assinada: Potenza assegnata: Nominal power:</p>	<b>350 W</b>
	<p>Poids : Gewicht : Peso : Peso : Peso : Weight :</p>	<b>1.6 kg</b>

		<b>ø 150 mm</b>
--	--	-----------------

	<p>Niveau de pression acoustique : Niveau akoestische druk : Nível de presión acústica : Nível de pressão acústica : Livello di pressione acustica : Acoustic pressure level :</p>	<b>82.3 dB (A)</b>
--	--	--------------------

	<p>Niveau de puissance acoustique : Niveau akoestisch vermogen : Nível de potencia acústica : Nível de potência acústica: Livello di potenza acustica: Acoustic power level :</p>	<b>90.3 dB (A)</b>
--	---	--------------------

**NIVEAU SONORE D'EMISSION:**

**A VIDE**

Pression acoustique LpA poste opérateur **82.3 dB**  
3

Puissance acoustique LWA **90.3 dB**  
3

Valeurs déterminées suivant le code d'essai de l'annexe B de la norme EN 60745 avec emploi des normes de base ISO 11201 et ISO 3744.  
 Les niveaux de pression acoustique obtenus in situ dépendent:

- Des niveaux réels de la machine considérées, en prenant en compte les incertitudes déclarées.
- Du local et de l'installation de la machine. Préférez une pièce dont l'acoustique est plus feutrée. Evitez les pièces vide à grande résonance. Placez vous auprès d'une fenêtre le cas échéant.
- Des outils montés, des pièces travaillées, des réglages choisis,...

<p>Niveau de vibration : Vibrationspegel Hand/Arm : Nível de vibración mano/brazo : Livello di vibrazione mano/braccio : Nível de vibração mão/braço : Hand/arm vibration level :</p>		<b>3.221 m / s<sup>2</sup></b>
---	--	--------------------------------

**VIBRATIONS:**

Total des valeurs de vibration (somme vectorielle des trois directions) déterminée selon EN 60745 :

a **3.221 m/**  
s2  
Incertitude K **1,5 m/s2**

L'amplitude d'oscillation peut être utilisée comme valeur de comparaison d'outils électroportatifs.

Attention : si l'outil électroportatif est utilisé pour d'autres applications, avec d'autres outils de travail, l'amplitude d'oscillation peut être différente.



	Soumis à recyclage :	X
	Niet wegwerpen :	
	Sottoposti a riciclaggio :	
	Sujeitos à reciclagem :	
	Sottoposti a riciclaggio :	
Subjected to recycling :		

	Danger :	X
	Gevaar :	
	Peligro :	
	Perigo :	
	Pericolo :	
	Danger :	

**FR-RECYCLAGE DES DÉCHETS:**

LES OUTILS, ACCESSOIRES ET LEUR EMBALLAGES DOIVENT SUIVRE UNE VOIE DE RECYCLAGE ADAPTÉE. CONFORMÈMENT AUX DIRECTIVES EUROPÉENNES 2012/19/UE ET 2006/66/CE, LES COMPOSANTS D'UN PRODUIT DOIVENT ÊTRE SÉPARÉS, COLLECTÉS, RECYCLÉS OU ÉLIMINÉS EN CONFORMITÉ AVEC LES RÉGLEMENTATIONS ENVIRONNEMENTALES EN VIGUEUR. LES APPAREILS, BATTERIES, PILES, HUILES, EMBALLAGES DEVRONT ÊTRE DÉPOSÉS DANS LES SYSTÈMES D'ÉLIMINATION DES DÉCHETS SPÉCIAUX TELS QUE DÉCHETTERIES. RENSEIGNEZ-VOUS AUPRÈS DE VOTRE COMMUNE POUR CONNAÎTRE L'ORGANISME LE PLUS PROCHE À MÊME DE RETRAITER OU DE COLLECTER CES DÉCHETS.

**NL-AFVAL RECYCLING:**

GEREEDSCHAP, ACCESSOIRES EN VERPAKKINGEN MOETEN VOLGEN EEN PAD GESCHIKT IS VOOR RECYCLING. VOLGENS DE EUROPESE RICHTLIJNEN 2012/19/UE EN 2006/66/CE, DE COMPONENTEN VAN EEN PRODUCT MOET WORDEN GESCHIEDEN, VERZAMELD, GERECYCLEERD OF VERWIJDERD IN OVEREENSTEMMING MET DE MILIEUVOORSCHRIFTEN. APPARATEN, BATTERIJEN, OLIE, MOET DE VERPAKKING WORDEN GEDEPONEERD IN DE AFVALVERWERKING AFVAL, ZOALS STORTPLAATSEN. NEEM CONTACT OP MET UW GEMEENTE NAAR DE DICHTSTBIJZIJNDE AGENTSCHAP KUNNEN HERHALEN OF HET VERZAMELEN VAN DEZE AFVALSTOFFEN TE VINDEN.

**ES-RECICLADO DE LOS RESIDUOS:**

LAS HERRAMIENTAS, LOS ACCESORIOS Y LOS ENVASES TIENEN QUE SEGUIR LA VÍA DE RECICLAJE ADECUADA. EN VIRTUD DE LAS DIRECTIVAS EUROPEAS 2012/19/UE Y 2006/66/CE, LOS COMPONENTES DE UN PRODUCTO DEBEN SEPARARSE, RECOGERSE, RECICLARSE O ELIMINARSE DE ACUERDO CON LAS REGLAMENTACIONES MEDIOAMBIENTALES VIGENTES. LOS APARATOS, BATERÍAS, PILAS, ACEITES, ENVASES DEBERÁN LLEVARSE A LOS CENTROS DE ELIMINACIÓN DE RESIDUOS ESPECIALES TALES COMO LOS ECOPARQUES. PEDIR INFORMACIÓN AL MUNICIPIO PAR CONOCER EL CENTRO MÁS CERCANO APTO PARA RECICLAR O RECOGER DICHOS RESIDUOS.

**PT-RECICLAGEM DO LIXO:**

AS FERRAMENTAS, ACESSÓRIOS E SUAS EMBALAGENS DEVEM SEGUIR UM CANAL DE RECICLAGEM ADAPTADO, CONFORMEMENTE AS DIRETIVAS EUROPEIAS 2012/19/UE E 2006/66/CE, OS COMPONENTES DE UM PRODUTO DEVEM SER SEPARADOS, RECOLHIDOS, RECICLADOS OU ELIMINADOS DE ACORDO COM AS REGULAMENTAÇÕES AMBIENTAIS EM VIGOR. OS APARELHOS, BATERIAS, PILHAS, ÓLEOS E EMBALAGENS DEVERÃO SER DEPOSITADOS NOS SISTEMAS DE ELIMINAÇÃO DE DETRITOS ESPECIAIS, TAIS COMO UNIDADES DE TRIAGEM DE DETRITOS. INFORMAR-SE JUNTO AO SEU CONCELHO MUNICIPAL PARA CONHECER O ÓRGÃO MAIS PRÓXIMO HABILITADO A EVACUAR OU RECOLHER ESTES DETRITOS.

**IT-RICICLAGGIO DEI RIFIUTI:**

GLI APPARECCHI, I LORO ACCESSORI ED IMBALLAGGI DEVONO ESSERE SOTTOPOSTI AD UN PROCESSO DI RICICLAGGIO APPROPRIATO. IN CONFORMITÀ CON LE DIRETTIVE EUROPEE 2012/19/UE E 2006/66/CE, I COMPONENTI DI UN PRODOTTO DEVONO ESSERE SEPARATI, RACCOLTI, RICICLATI O SMALTITI IN CONFORMITÀ CON LE NORMATIVE AMBIENTALI IN VIGORE. GLI APPARECCHI, LE BATTERIE, LE PILE, GLI OLI, GLI IMBALLAGGI DOVRANNO ESSERE CONFERITI NEI SISTEMI DI SMALTIMENTO DEI RIFIUTI SPECIALI COME LE ISOLE ECOLOGICHE. INFORMARSI PRESSO IL PROPRIO COMUNE PER SAPERE QUAL È L'ENTE PIÙ VICINO IN GRADO DI FARE IL TRATTAMENTO O LA RACCOLTA DIFFERENZIATA DI QUESTI RIFIUTI

**EN-WASTE RECYCLING:**

THE TOOLS, ACCESSORIES AND THEIR PACKAGING MUST USE AN APPROPRIATE RECYCLING CHANNEL. IN COMPLIANCE WITH EUROPEAN DIRECTIVES 2012/19/UE AND 2006/66/CE, A PRODUCT'S COMPONENTS MUST BE SEPARATED, COLLECTED, RECYCLED OR ELIMINATED IN ACCORDANCE WITH THE ENVIRONMENTAL REGULATIONS IN FORCE. THE APPLIANCE, BATTERIES, OILS AND PACKAGING MUST BE DEPOSITED IN THE SPECIAL WASTE ELIMINATION SYSTEMS SUCH AS THE WASTE COLLECTION CENTRES. ASK YOUR COMMUNE FOR INFORMATION ON THE NEAREST ORGANISATION IN A POSITION TO REPROCESS OR COLLECT THIS WASTE

		X
--	--	---

	Conformité européenne :	X
	Voldoet aan de EG-normen :	
	Cumple con las directivas CE :	
	Conforme às normas CE :	
	Conforme alle norme CE :	
Conforms to EC standards :		





# BOS 5.0

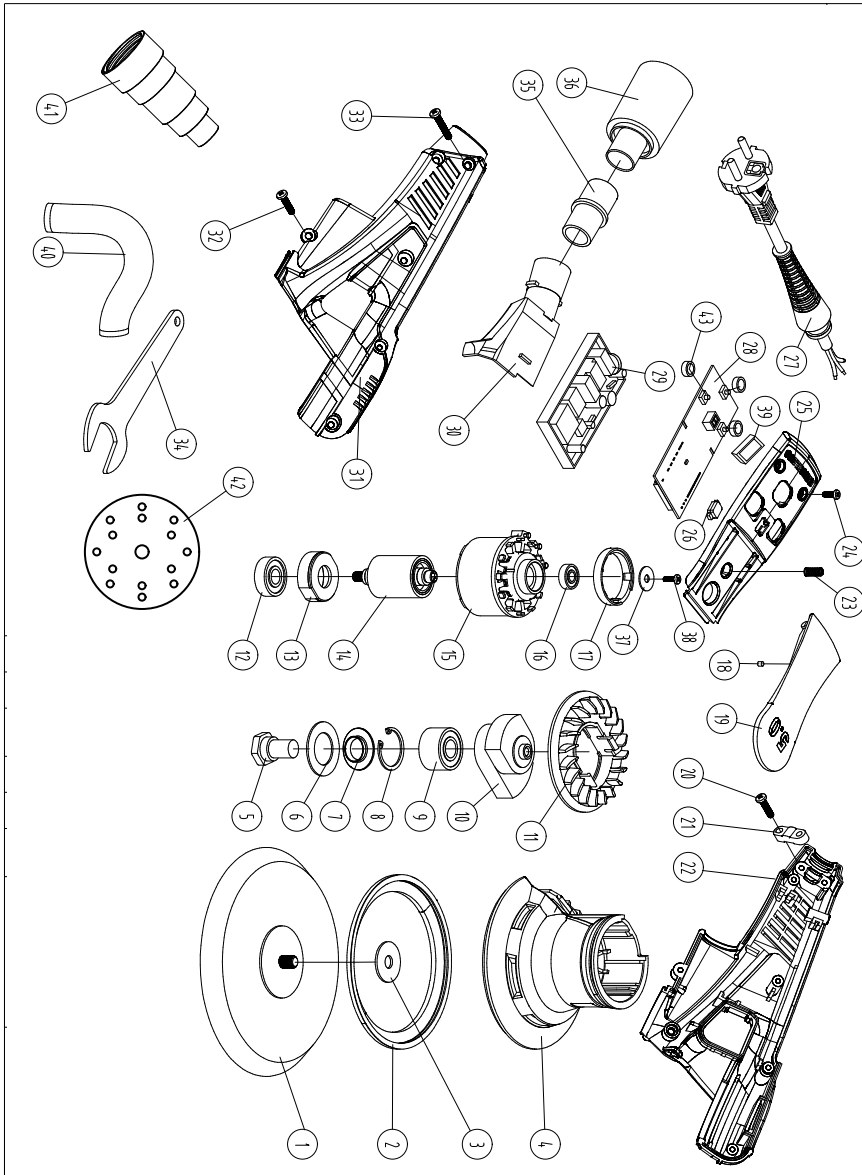

DECLARATION CE DE CONFORMITE  
DECLARACION DE CONFORMIDAD  
DICHIARAZIONE DI CONFORMITA

VERKLARING VAN OVEREENSTEMMING  
DECLARAÇÃO DE CONFORMIDADE  
DECLARATION OF CE CONFORMITY

Le soussigné,  
Ondergetekende,  
El suscrito,  
O abaixo assinado,  
Il sottoscritto,  
The undersigned,

**MPO**

192, Avenue Yves Farge - 37700 St. Pierre-des-Corps - FRANCE  
Tél. : 02 36 16 71 46 - Fax : 02 36 16 71 40

Déclare par la présente que,  
Verklaart hiermede dat,  
Declara por la presente que,  
Declara pela presente que,  
Dichiare che,  
Declares that,

**CODE**

MPO / BOS 5.0 / 180715 / S1A-HD02-150

**Ponceuse / Sander / Schleifmaschine / Schuurmachine / Lijadora / Levigatrice / Lixadeira**

Est conforme et satisfait aux normes CE:  
In overeenstemming is met en Voldoet aan EG richtlijnen:  
Cumple con la directivas de la CE:  
Respeita e está em conformidade com as normas CE:  
È conforme alle direttive CEE:  
Complies with the EEC standards:

Machine : 2006/42/EC 2014/30/EU 2011/65/EU & 2015/863/EU

Machine:  
Máquina:  
Máquina:  
Macchina:  
Machine :  
EN IEC 55014-1:2021  
EN IEC 55014-2:2021  
EN IEC 61000-3-2:2019/A1:2021  
EN 61000-3-3:2013/A2:2021  
EN 62841-1:2015+AC:15/A11:2022  
EN 62841-2-4:2014















**SIGMA**

Présidente de MPO  
Représentée par son Président :  
10/02/2026  
Fait à St. Pierre-des-Corps

Personne autorisée à  
constituer le dossier technique :  
Christophe HUREL



**MEJIX** 180715  
**BOS 5.0**

 350W	 230V-50Hz	 600-1000mm	 7.8 kg		
 ø150 mm					

IP20

N° Serie / Serial:   
S1A-HD02-150

MPO - 192, Avenue Yves Farge - 37700 St. Pierre-des-Corps

Made in P.R.C.



# 3 ANS GARANTIE

## BON DE GARANTIE

**1 - Objet de la garantie :**  
La garantie porte exclusivement sur les vices de fabrication ou les vices de matières.  
Elle nous oblige à l'échange ou à la réparation des pièces reconnues hors d'usage.

**2 - Durée de la garantie :**  
La garantie est de 36 mois à dater de la livraison du matériel à l'utilisateur (facture ou ticket de caisse à fournir). Les échanges ou réparations faites au titre de la garantie ne peuvent avoir pour effet de prolonger celle-ci.  
Les frais de port ALLER sont à la charge de l'utilisateur.

**3 - Réserves :**  
La garantie ne s'applique en aucun cas aux réparations effectuées en dehors de nos réparateurs agréés.  
En aucun cas, durant la période de garantie, le matériel ne devra être démonté.

## GARANTIEKAART

**1 - Doel van de garantie:**  
De garantie heeft uitsluitend betrekking op fabricagefouten of gebreken in materialen.  
Het dwingt ons om uit te wisselen of reparatie van erkende onbruikbare onderdelen.

**2 - Duur van de garantie:**  
De garantie bedraagt 36 maanden vanaf de levering van apparatuur voor de gebruiker (factuur of kassabon te verstrekken).  
De uitwisseling of reparaties onder garantie niet te verlenen.  
GO verzendkosten zijn voor rekening van de gebruiker.

**3 - Reserves:**  
De garantie geldt niet in alle reparaties die buiten onze goedgekeurd reparateurs.  
In ieder geval gedurende de garantie, moet het materiaal worden verwijderd.

## TARJETA DE GARANTÍA

**1 - Objeto de la garantía:**  
La garantía sólo se referirá a los defectos de fabricación o defectos en los materiales.  
Nos obliga a cambiar o reparación de las piezas fuera de servicio reconocido.

**2 - Duración de la garantía:**  
La garantía es de 36 meses a partir de la entrega de equipos para el usuario (factura o recibo que se den).  
Los intercambios o reparaciones bajo garantía no tendrá que prolongarse.  
GO gastos de envío correrán a cargo del usuario.

**3 - Reservas:**  
La garantía no se aplica en todas las reparaciones realizadas fuera de nuestros talleres de reparación autorizados.  
En cualquier caso, durante el período de garantía, el material debe ser removido.

## CARTÃO DE GARANTIA

**1 - Finalidade da garantia:**  
A garantia só relacionar com defeitos de fabricação ou defeitos em materiais.  
Ela nos obriga a troca ou reparo de peças inservíveis reconhecidos.

**2 - Duração da Garantia:**  
A garantia é de 36 meses a partir da entrega de equipamentos para o usuário (factura ou recibo a ser fornecido).  
Trocas ou reparos sob a garantia não terá que prorrogá-la.  
GO porte serão custeadas pelo usuário.

**3 - Reservas:**  
A garantia não se aplica a quaisquer reparos feitos fora das nossas oficinas aprovadas.  
Em qualquer caso, durante o período de garantia, o material deve ser removido.

## GARANZIA

**1 - Oggetto della garanzia:**  
La garanzia si riferisce esclusivamente alla difetti di fabbricazione o difetti nei materiali.  
Ci costringe a scambio o la riparazione di parti inutilizzabili riconosciuti.

**2 - Durata della garanzia:**  
La garanzia è di 36 mesi dalla consegna delle attrezzature per l'utente (fattura o ricevuta da fornire).  
Scambi o riparazioni in garanzia non sarà necessario prolungarla.  
GO spese di spedizione sono a carico dell'utente.

**3 - Riserve:**  
La garanzia non si applica in tutte le riparazioni effettuate al di fuori dei nostri riparatori autorizzati.  
In ogni caso, durante il periodo di garanzia, il materiale deve essere rimosso.

## WARRANTY

**1 - Scope of the warranty :**  
The warranty shall only apply to manufacturing defects or material defects.  
We are obliged to exchange or repair parts that are identified as being unusable

**2 - Lifetime warranty :**  
The warranty shall be valid for 36 months from the delivery date of the equipment to the user (invoice or bill receipt must be provided).  
Exchanges or repairs carried out under the warranty shall not extend the original warranty period.  
The user shall be responsible for original shipping charges.

**3 - Reservations :**  
The warranty shall not under any circumstances cover repairs carried out by a non-authorized repairer.  
The equipment should not be dismantled under any circumstances during the warranty period.

Date d'achat	Référence machine	Cachet du distributeur
Datum van aankoop	Machine referentie	Dealer stempel
Fecha de compra	Referencia de la máquina	Comerciante de sellos
Data da compra	Referência de máquina	Selo Revendedor
Data di acquisto	Riferimento macchina	Timbro del rivenditore
Purchase date	Machine code	Distributor's stamp

## SERVICE APRÈS VENTE - AFTER SALE SERVICE

MPO - 192, Avenue Yves Farge - 37700 St. Pierre-des-Corps - FRANCE - Tél. : 02 36 16 71 46 - Fax : 02 36 16 71 40



ción  
a de  
a de  
ndrá

rea-  
tori-



.ts



anty  
oing  
over





MPO

Une société du groupe **SIGMA**

192, Avenue Yves Farge  
37700 St. Pierre-des-Corps  
FRANCE

[www.mejix.fr](http://www.mejix.fr)  
[contact@mpoutillage.net](mailto:contact@mpoutillage.net)

